

K40 Enclosure Assembly Guide

Version 1.4 11/21/2007

This document describes the assembly and checkout of the K40 enclosure. It is assumed that the builder has already assembled the K40 kit and has determined that it is operating properly. If you have already attached the LCD to the K40 PCB you will likely have to redo the wiring harness with the wire lengths given in this document.

All you need to complete the assembly are a soldering iron, solder, wire cutters, wire strippers, philips screwdriver, and a pair of long nose pliers. A volt ohmmeter is recommended. Also covered in this guide is the installation of the optional K40FILT RTTY module.

K40 Enclosure Bill of Materials

QTY	Ref Designator	Description	Chk
4	J1, J2, J3, J4	RCA Phono Jack	
1	J5	1/8" Stereo Jack	
1	J6	2.1 mm Power Jack	
1	C1	.047uf ceramic capacitor	
114"	White (9.5 ft)	26 ga wire for harness	
24"	Red (2 ft)	26 ga wire for harness	
24"	Black (2 ft)	26 ga wire for harness	
1	N/A	Knob 1/4" Shaft	
1	N/A	Enclosure top	
1	N/A	Enclosure bottom	
12	N/A	4-40 Screws (Silver)	
5	N/A	4-40 Screws (Black)	
4	N/A	Cable Ties	

Kit Assembly

- 1) Verify and check off all components against the bill of materials listed above. If there are shortages notify K1EL by email as soon as possible and we'll send out any missing parts.
- 2) We'll start out by building the wiring harness. Cut each length as directed, strip 1/4 inch from both ends and then tin the wire ends. Use a minimal amount of solder for the tinning process since one end of each wire will attach to the PC board and must be able to fit through the designated PCB hole. Push one end of each wire through the specified hole, turn the board over, and solder the lead to the pad.
- 3) Cut a 3" white wire, and attach it to the K40 "DIT" pad.
- 4) Cut a 3" white wire, and attach it to the K40 "DAH" pad.
- 5) Cut two white wires, 3 1/2" and 6" insert one end of each into the K40 "G" pad (next to ENC1) and solder.
- 6) Cut a 4 1/4" white wire and attach it to the K40 "PTT" pad.
- 7) Cut a 3 1/4" white wire and attach it to the K40 "KEY" pad.
- 8) Cut a 3 1/2" white wire and attach it to the K40 "G" pad between PTT and KEY.
- 9) Cut a 6" white wire and attach it to the K40 "ENC1" pad.
- 10) Cut a 6" white wire and attach it to the K40 "ENC2" pad.
- 11) Cut a 7" white wire and attach it to the K40 "7" pad. (LCD connection)
- 12) Cut a 7" white wire and attach it to the K40 "6" pad. (LCD connection)
- 13) Cut a 7" white wire and attach it to the K40 "5" pad. (LCD connection)
- 14) Cut a 6 3/4" white wire and attach it to the K40 "4" pad. (LCD connection)
- 15) Cut a 6 1/2" white wire and attach it to the K40 "E" pad. (LCD connection)
- 16) Cut a 6 1/2" white wire and attach it to the K40 "W" pad. (LCD connection)
- 17) Cut a 6 1/2" white wire and attach it to the K40 "R" pad. (LCD connection)

- 18) Cut a 6½" white wire and attach it to the K40 "B" pad. (LCD connection)
- 19) Cut a 6½" RED wire and attach it to the K40 "V" pad. (LCD connection)
- 20) Cut a 6½" BLACK wire and attach it to the K40 "G" pad. (LCD connection)

RTTY Note: If you choose not to install the RTTY board you can skip the RTTY wires. If you think you might want to add it in the future, install the wires in the harness but only strip one end. The other end will be left unattached and tied off later.

- 21) RTTY option: Cut a 4.5" white wire and attach it to the K40 "RY" pad.
 - 22) RTTY option: Cut a 4" white wire and attach it to the K40 "G" pad next to RY.
 - 23) RTTY option: Cut a 5" white wire and attach it to the TI pad (see figure below)
 - 24) RTTY option: Cut a 4.5" white wire and attach it to the TR pad (see figure below)
- Note that neither TR or TI are labeled by silkscreen legend on the K40 PCB**
- 25) RTTY option: Cut a 4" RED wire and attach it to the 5V pad (see figure below)
 - 26) RTTY option: Cut a 4" BLACK wire and attach it to the G pad (see figure below)

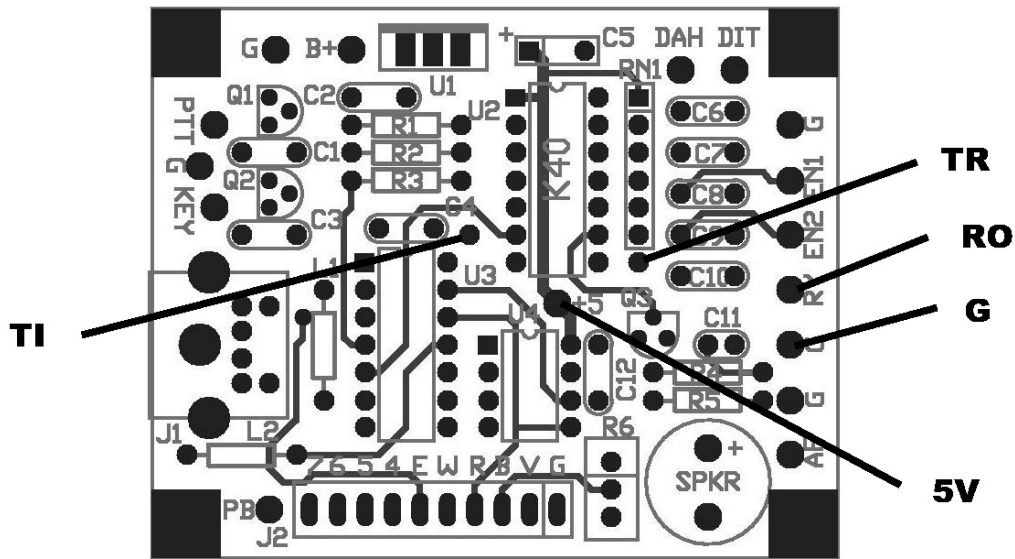

Fig 1 - RTTY wire connections

- 27) Cut a 6" RED wire and attach it to the K40 "B+" pad.
- 28) Cut a 6" BLACK wire and attach it to the K40 "G" pad next to B+.
- 29) Attach designated wires to the paddle connector as shown. For the ground connection, use the 3½" white wire that shares a "G" pad with the 6" white wire.

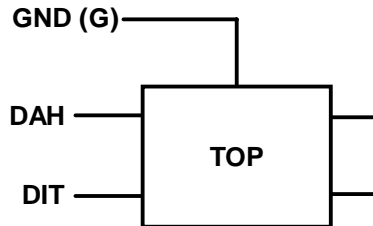

Fig. 2 - Paddle Connector

- 30) Attach rotary encoder as shown: For the ground connection, use the 6" white wire that shares a "G" pad with the ground connection on the paddle connector. Neatly wrap each wire around the encoder pins and solder.

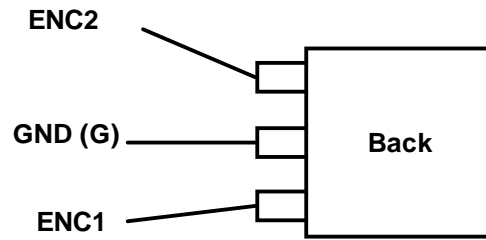

Fig. 3 - Rotary Encoder Connections

- 31) Attach LCD Display: Use the table below as a guide in connecting the K40 wires to the LCD display. Use care in soldering the wires to the display, use just enough solder to provide a good shiny connection. It is very easy to bridge two pads together if too much solder is used.

K40 Pad	LCD Display Pin
7	Pin 14 -Data 7
6	Pin 13 -Data 6
5	Pin 12 -Data 5
4	Pin 11 -Data 4
	Pins 7-10 No LCD connection
E	Pin 6 - Enable
W	Pin 5 - Write
R	Pin 4 - Register Select
B	Pin 3 - LCD Bias (VEE)
V	Pin 2 - Vcc (+5)
G	Pin 1 - VSS (Ground)

Table 1 - LCD Display Connection Chart

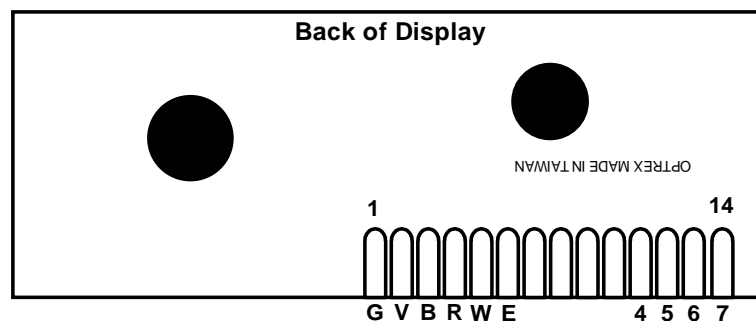

Fig. 4 Display Pinout

Double check that you have a black wire on LCD pin 1 and that it connects to the G pad on the K40. Check that you have a red wire on LCD pin 2 and that it connects to the V pad on the K40. If you get this wrong you can damage the display when you test it.

- 32) Backlight hookup: **NOTE: The current displays we are shipping have backlight already wired up internally so you can skip this section.** You can use the 5V supply as the backlight power source and use a 390 ohm ¼ watt

resistor in series which limits the backlight current to about 10 ma. It gives me a dim backlight that is good for low light situations. If you want more light use a smaller resistor, a 47 ohm ½ watt resistor is the lowest limit. The maximum backlight current specified in the data sheet is 180ma at 4.4 volts. Note that if you want to run at max brightness (max current) I recommend attaching the 7805 regulator to the enclosure for heat sink purposes.

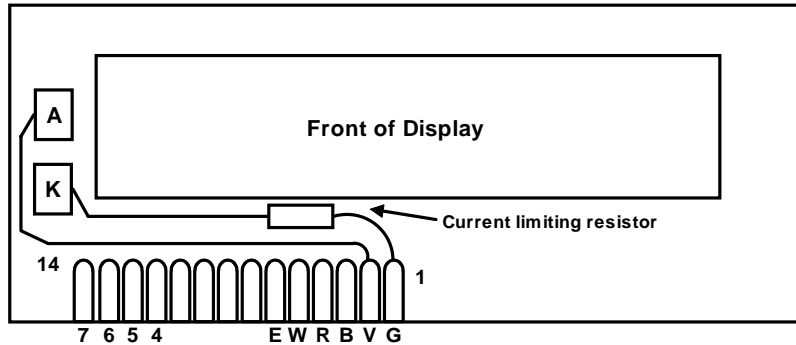

Fig 5 - Wiring of the LCD backlight

- 33) Temporarily attach a DC power supply to the RED wire that goes to B+ on the K40PCB and the adjacent BLACK wire that goes to G for testing. RED LEAD GOES TO PLUS, BACK LEAD GOES TO GROUND **DOUBLE CHECK!!** Anything from 8 to 16 volts will work, I use a 9 volt battery.
- 34) Turn the display pot 20 turns clockwise to make sure the LCD bias starts out at ground potential. You can verify this with an ohmmeter.
- 35) Turn on the supply and you should hear a sidetone 'R' and see the K40 sign on screen:

```
K1EL K40 v E
WK40 v E CW
```

- 36) If the display does not appear, carefully check the wiring between display and K40 PCB. We are skipping the K40 checkout phase since we assume that you have already tested it beforehand.
- 37) Install the 2.1mm power connector in the appropriate location on the back panel.
- 38) Remove the nut, washer, and ground lug from the four RCA jacks. I bend the ground lug slightly so that when it is assembled the lug is not flush to the enclosure. Now install the four jacks in the back panel with a lug, washer and nut. You will have to hold the jack body with a pair of pliers while tightening the nut, use a 3/8 nut driver if you have one.

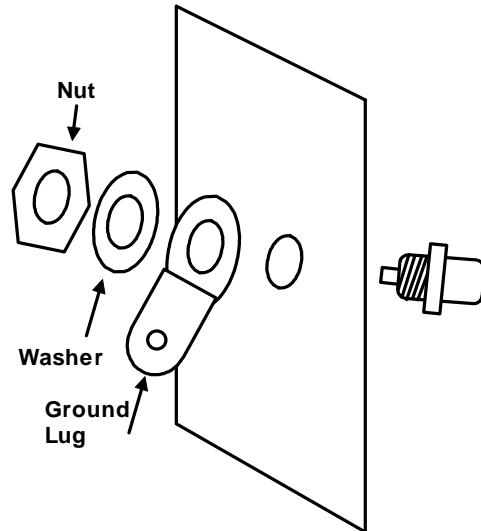

Fig. 6 – RCA Jack Hardware Order

- 39) Mount the K40 PCB in the enclosure base with four 4-40 screws. Orient the board so that the keyboard connector aligns with the keyboard opening on the back panel. Dress the leads so that they don't get caught or pinched under the PCB board. The screws toward the back are tricky to install. I place the screws in position with a pair of long nose pliers and then carefully tighten it into place with a thin shaft Philips screwdriver.
- 40) Install the paddle connector in the location dictated by the back panel. Tighten the holding ring with a pair of pliers. It's easy to scratch the paint if you aren't careful. I put a dab of Loctite on the threads to prevent the ring from loosening.
- 41) Attach the RED wire (from K40 B+) and BLACK wire (from G) to the power connector as shown below. Install the .1 uF capacitor across the power pins as shown. Insure a good physical connection without shorts before soldering.

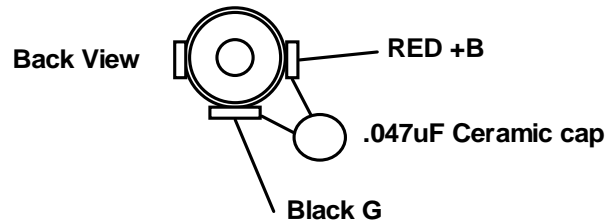

Fig. 7 Power Connector Wiring

- 42) Then locate the KEY and PTT wires and solder each wire to the center conductor of the appropriate RCA jack. Check the silkscreen on the back panel for location. Solder the wire that goes to the G pad between the KEY and PTT pads to the RCA jack ground lug closest to the K40 PCB.

- 43) RTTY: Cut four 6" wires and attach one to the center pin of each remaining RCA jack (2). Solder the other two to the two solder lugs from the RCA jacks. Install the jacks/wires/lugs in the FSK OUT and AF IN holes in the enclosure.
- 44) RTTY: Attach wires to the RTTY filter board as shown in the following diagram:

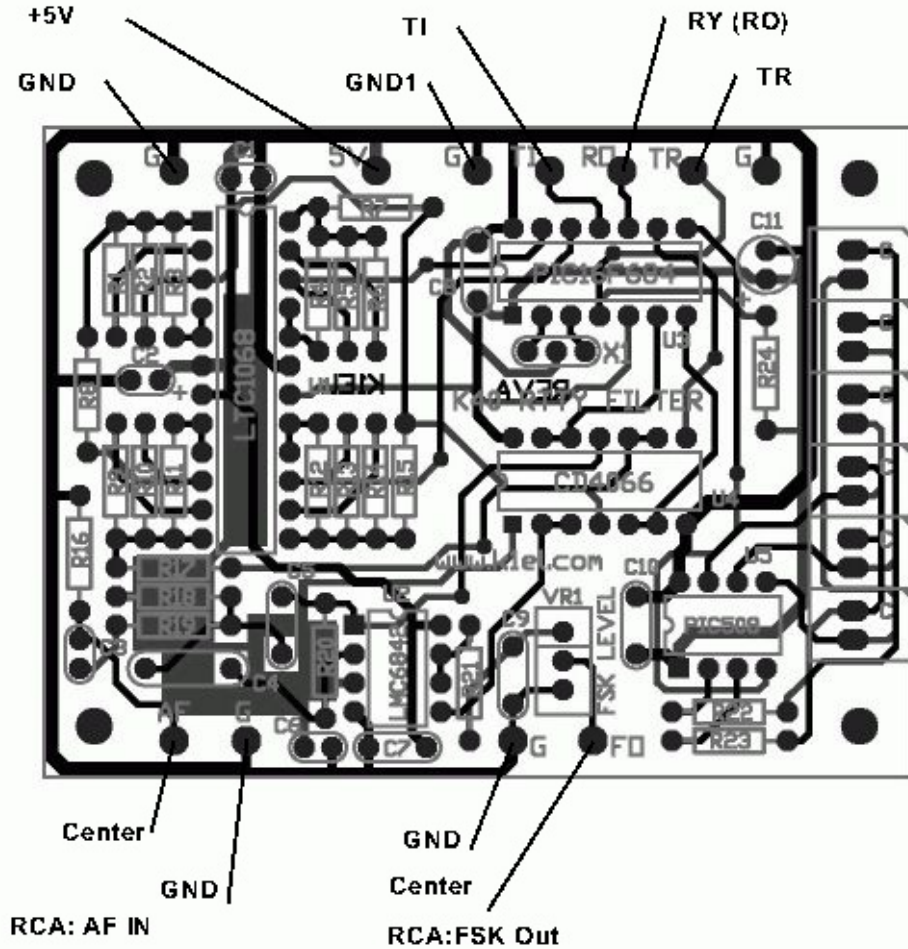

Fig. 8 – RTTY Wiring Diagram

- Take your time and verify that you have the correct wire before soldering. The most important wires again are the Red and Black supply leads. The AF IN and FSK Out G pads go to the respective ground lugs on the back panel mounted RCA jacks. The ground wire labeled GND1 connects to the G pad on the K40PCB next to the AF pad.
- 45) RTTY: Install the filter board in the enclosure base with four 4-40 screws, Make sure that the LED array faces away from the back panel.
- 46) Attach the LCD display with four 4-40 screws and rotary encoder to the top enclosure panel. The LCD is oriented with the connection side facing down, see photo below.
- 47) Bundle the wires together to form a wiring harness. If you are not installing the RTTY filter board at this time bundle those wires together and tie them with a cable tie. Use some electrical tape on the end to prevent shorting against the housing. The photo below shows the general harness layout. Make sure you allow enough wire relief to allow the top panel to be put in place without interference. When you are happy with the harness, use the four cable ties to hold the harness together.

- 48) Attach the Speed control knob using a small screwdriver. Orient the knob so the set screw will tighten against the flat side of the control shaft. You will have to turn the set screw in almost all the way to meet the shaft.
- 49) Attach top cover using the black 4-40 screws.
- 50) Power Plug Wiring

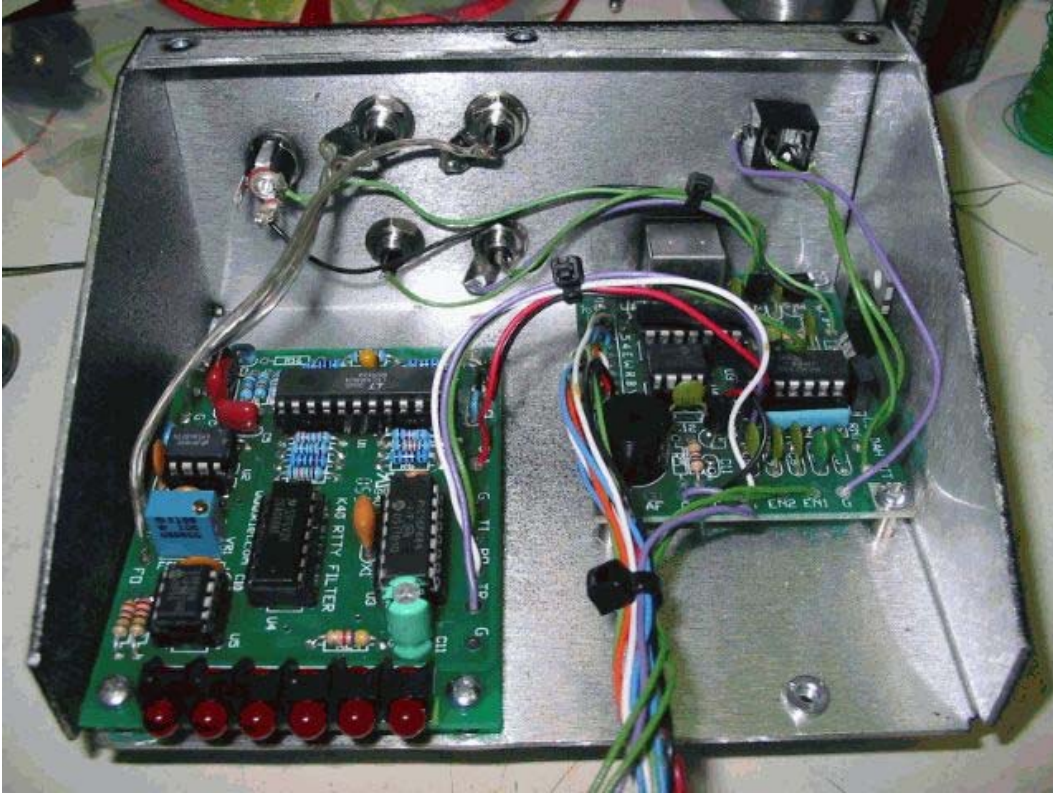

Fig. 9 – Interior of K40 enclosure showing wiring harness



Fig 10 – Wiring Harness to LCD and Speed Control

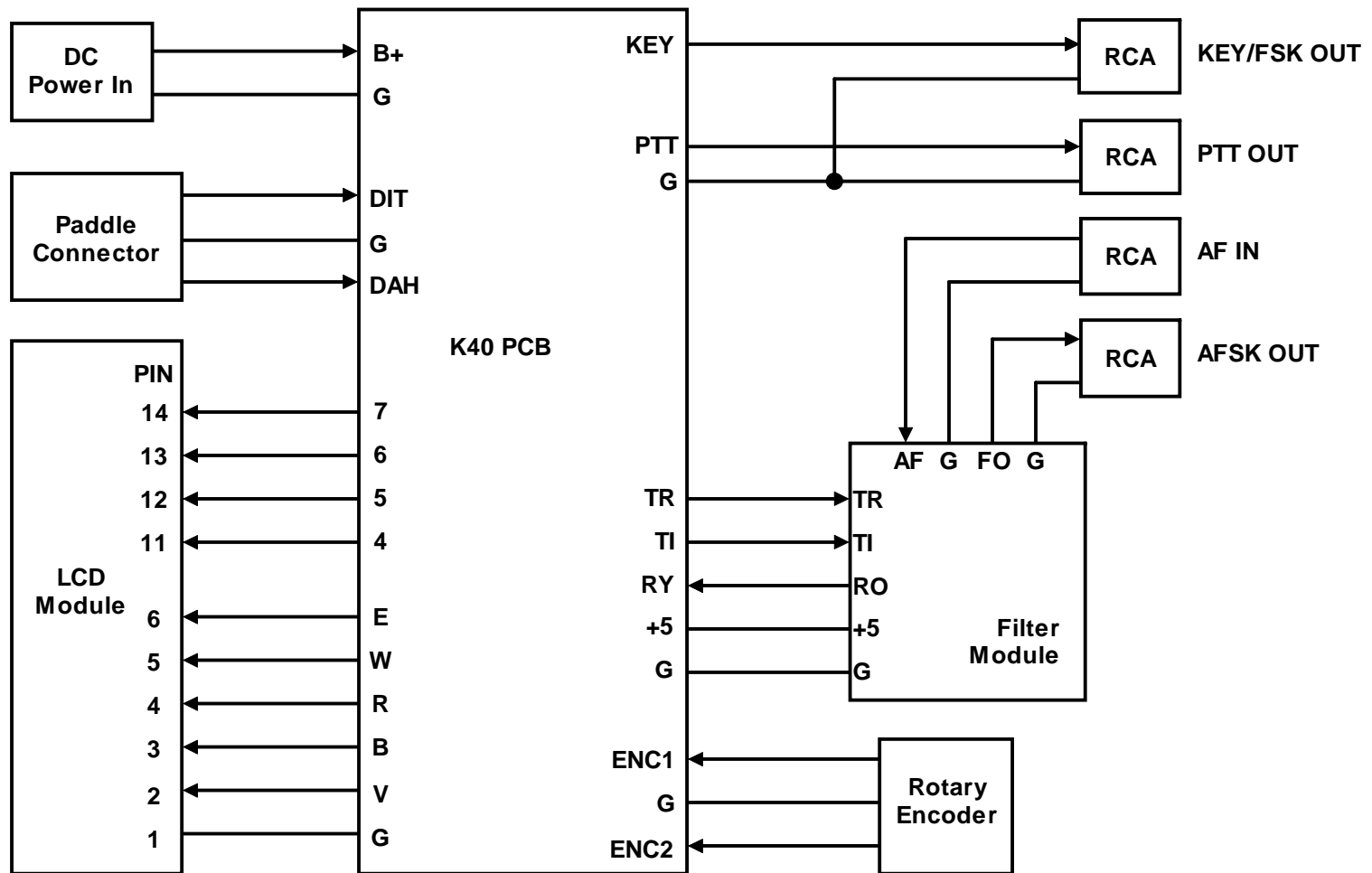

Figure 11 – K40 Enclosure Hook Up Diagram

Kit Checkout

At this point almost all of the components have been tested so we are just verifying that everything still works after being installed in the enclosure. Make up a power cable using the supplied 2.1mm power plug. Be sure that you connect + to the center conductor of the power plug. The K40 does not have a polarity protection diode so you need to be careful. I have accidentally reverse biased 7805 regulators for a short time and they have survived but I don't recommend it.

Connect your keyboard to the K40 and power up the box. Check that the display operates and that you can type on the keyboard and generate CW. Characters will appear on the display as you type. More detailed checkout info can be found in the K40 Manual.

<http://k1el.tripod.com/k40info.html>

Detailed test out information for the RTTY Filter board can be found in the K40 FILT manual.

<http://k1el.tripod.com/k40filtinfo.html>